



## DESCRIPTION

The 704 is an Automatic Mains Failure module with generator monitoring, protection and start facilities. It utilises advanced surface mount construction techniques to provide a compact yet highly specified module.

Operation of the module is via three pushbuttons mounted on the front panel with STOP, MANUAL and AUTO positions. Selection of the 'Auto' mode is confirmed by LED indicator, and monitors the incoming mains supply (3 phase or single phase). Should the incoming AC mains supply fall below a configurable pre-set limit (*180V default*), the generator will be started, and load transferred to the gen-set.

When the AC mains supply returns to within limits, the module will wait for a configurable, pre-set stabilisation period, and then transfer load back to the mains. The engine will be instructed to stop after a cool-down period.

The module's microprocessor provides a comprehensive list of timers and functions, and access to the settings is via a small Configuration Switch on the rear of the module. Parameter settings can be adjusted using the front panel pushbuttons once in Configuration Mode.

The module monitors the engine and provides the following functions:

- Automatic Start with 3 start attempts and Automatic Crank Disconnect - with adjustable Start and Stop Timers and Fail to Start indication.
- Configurable Pre-heat and Energise to Stop functions.
- Low Oil Pressure and High Engine Temperature Shutdown.
- Overspeed and Underspeed (frequency) protection.
- Charge Fail alarm
- Two fully configurable auxiliary inputs.
- Adjustable Warming and cooling timers
- Adjustable Mains Fail voltage level
- Change-over contactor control.

All alarms are indicated by high visibility red LED's.

Issues such as environmental compliance and EMC have been carefully engineered into the design. Advanced features such as Protected Solid State Outputs mean that there are no moving parts or contacts to burn out.

## OPERATION

**Stop mode** - This is used to stop the engine when it is running and to cancel 'Auto' mode. It is also used to reset any Shutdown alarm conditions.

**Manual mode** - This is used to manually start and run the engine. It can be stopped by pressing the Stop button.

**Auto mode** - This selects the automatic mode of operation, in which the module will await a mains failure. Once detected, the module will initiate its pre-configured start sequence, observing the Start Delay Timer before starting the engine. When the mains supply returns, the module will initiate its pre-configured stopping sequence.

## FEATURES

- **Micro-processor based design**
- **Automatic Engine Starting and Stopping**
- **Automatic Shutdown on Fault Condition**
- **Configurable via front panel**
- **Simple pushbutton controlled operation**
- **Configurable Digital Inputs**
- **Configurable Solid State Outputs**
- **Configurable Timer Settings**
- **Solid State Fuel and Crank Outputs**
- **External Remote Start Input**
- **LED Alarm indication**
- **Start/Stop Delay Timer**
- **Warm-up/Cooling Timer**
- **Energise to Stop Timer**
- **Single/Three phase mains sensing**
- **Load contactor control Solid State Outputs**
- **Pre-heat Timer**
- **Over Speed Shutdown**
- **Optional Underspeed Protection**
- **Low Oil Pressure Shutdown**
- **High Engine Temp Shutdown**
- **Optional Crank Disconnect from Oil Pressure**



## SPECIFICATION

### DC Supply:

8 to 35 V Continuous.

### Cranking Dropouts:

Able to survive 0 V for 50 mS, providing supply was at least 10 V before dropout and supply recovers to 5V. *This is achieved without the need for internal batteries.*

### Max. Current:

Operating 50mA

Standby 10mA

### Alternator Input Range:

75(ph-N) to 277(ph-N) 3 Phase 4wire AC (+20%)

### Alternator Input Frequency:

50 - 60 Hz at rated engine speed (Minimum: 75V AC Ph-N) (Crank Disconnect from 15V Ph-N @ 20Hz) Overspeed +14% (+24% overshoot) Underspeed -20%

### Start Output:

1.2 Amp DC at supply voltage.

### Fuel Output:

1.2 Amp DC at supply voltage.

### Auxiliary Outputs:

1.2 Amp DC at supply voltage.

### Dimensions:

125 X 165 X 28 mm

### Charge Fail:

12V = 8V CF 24V = 16V CF

### Operating Temperature Range:

-30 to + 70°C

- **Compliant with BS EN 60950 Low Voltage Directive**
- **Compliant with BS EN 50081-2 EMC Directive**
- **Compliant with BS EN 50082-2 EMC Directive**

*The 700 series modules have been designed for **front panel mounting**. The module is fitted into the cut-out, and screw holes are provided for secure fixing.*

# CONFIGURATION

Configuration Mode is selected by operation of a small switch on the rear, left-hand edge of the PCB. This is partially hidden to prevent accidental operation. See *figs 1 and 2*

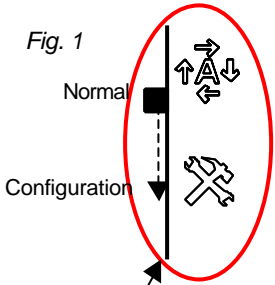

Once Configuration Mode is selected, the 'Auto' LED will commence rapid flashing. When in Configuration Mode all normal operation is suspended. The 'Stop' pushbutton can be used to select the LED 'code' that corresponds to the required function. The 5 left hand LED's will form the code. The 'Manual' pushbutton will allow the user to change the function parameters. The 3 right-hand LED's inform the user of the current setting for the chosen function. When the required parameters are displayed, pressing the 'Auto' button will save the new setting. The process is repeated for each function change. When configuration is complete, the Configuration Mode Selector Switch should be returned to the 'Normal' position. A key to configuration options is provided with the Installation Instructions supplied with module.

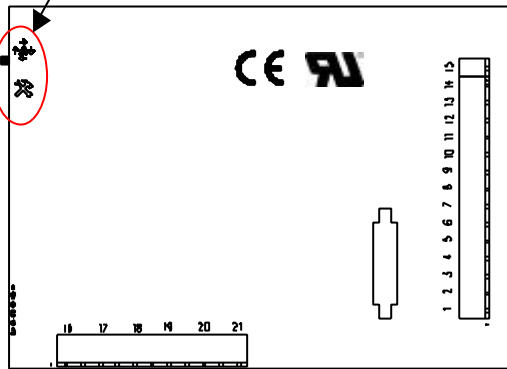

Fig. 2 Reverse of 704

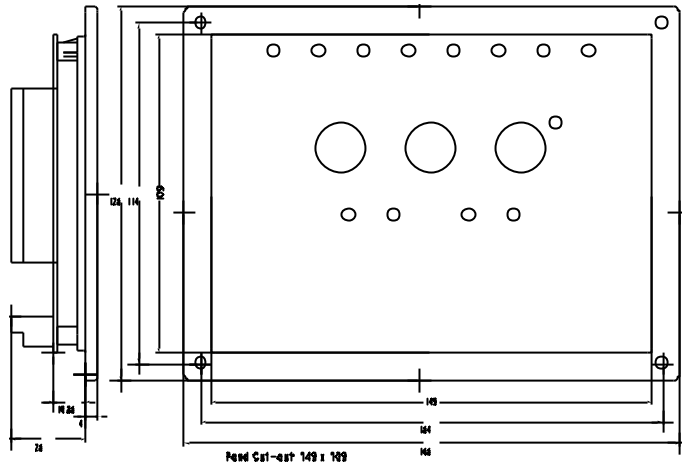
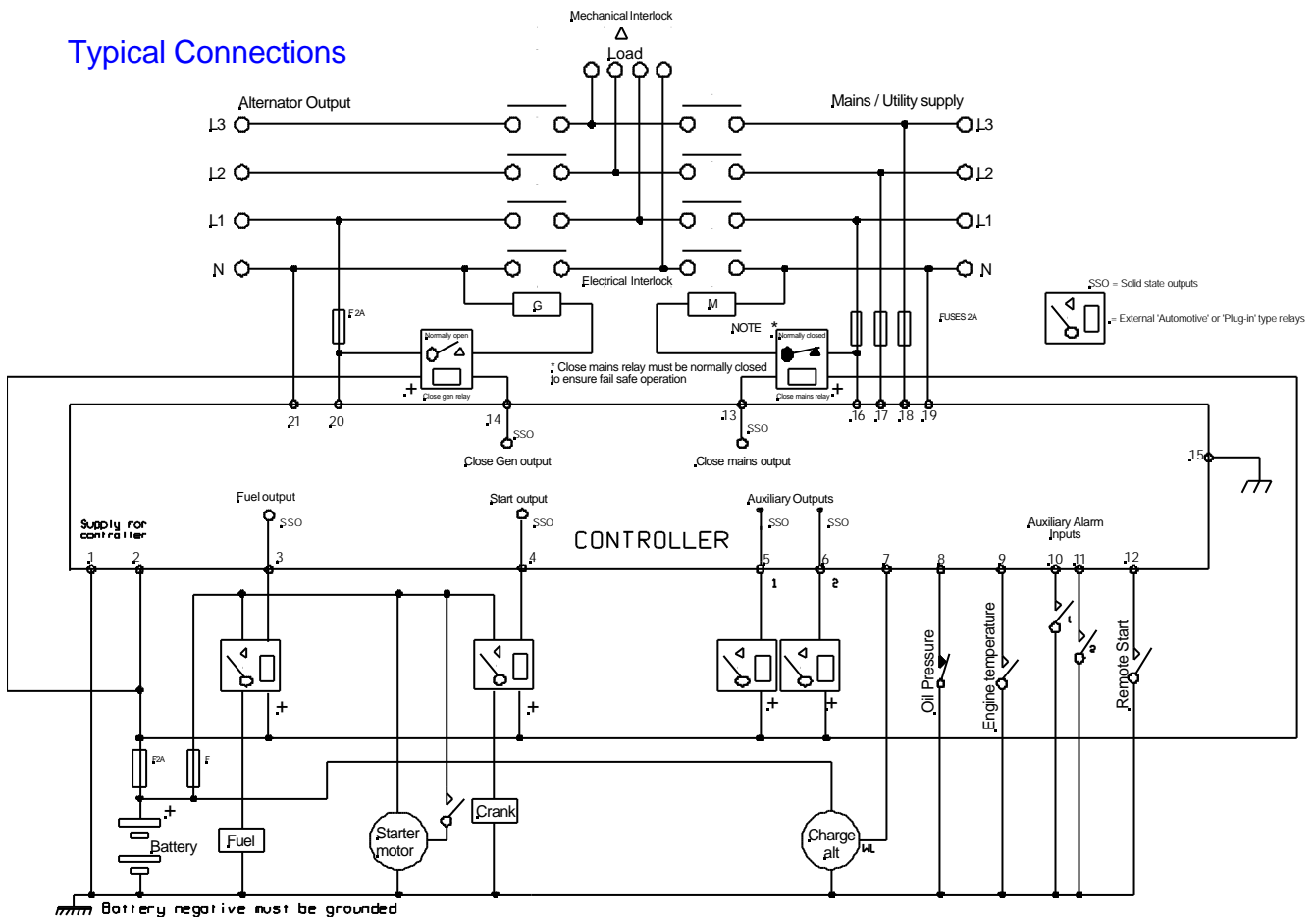

Fig. 3 Dimensions (mm)

## Typical Connections



**Deep Sea Electronics plc**  
 Highfield House, Hunmanby Industrial Estate, North Yorkshire, YO14 0PH, England  
 Tel: +44 (0) 1723 890099 Fax: +44 (0) 1723 893303 E-mail sales@deepseapl.com